

CUSTOMER TO SUPPLY DISCONNECT WITH ENCLOSURE TYPE 3R/NEMA 3R. DISCONNECT MUST BE RATED 230VOLT 30AMP UL489 OR UL98, HAVE 1 POLE FOR 120VOLT CIRCUITS AND 2 POLE FOR 208/230V CIRCUITS. CUSTOMER ALSO TO PROVIDE (QTY 1) 120VOLT 60HZ 1PHASE CIRCUIT WITH MINIMAL CIRCUIT AMPACITY OF 25AMPS AND A MAX BREAKER/FUSE OF 30AMPS. OR SUPPLY (QTY 1) 208/230VOLT 60HZ 1PHASE CIRCUIT WITH MINIMAL CIRCUIT AMPACITY OF 15AMPS AND A MAX BREAKER/FUSE OF 20AMPS. NOTE THAT EITHER THE 120 OR 208-230V CONFIGURATION REQUIRES A NEUTRAL & EQUIPMENT BOND

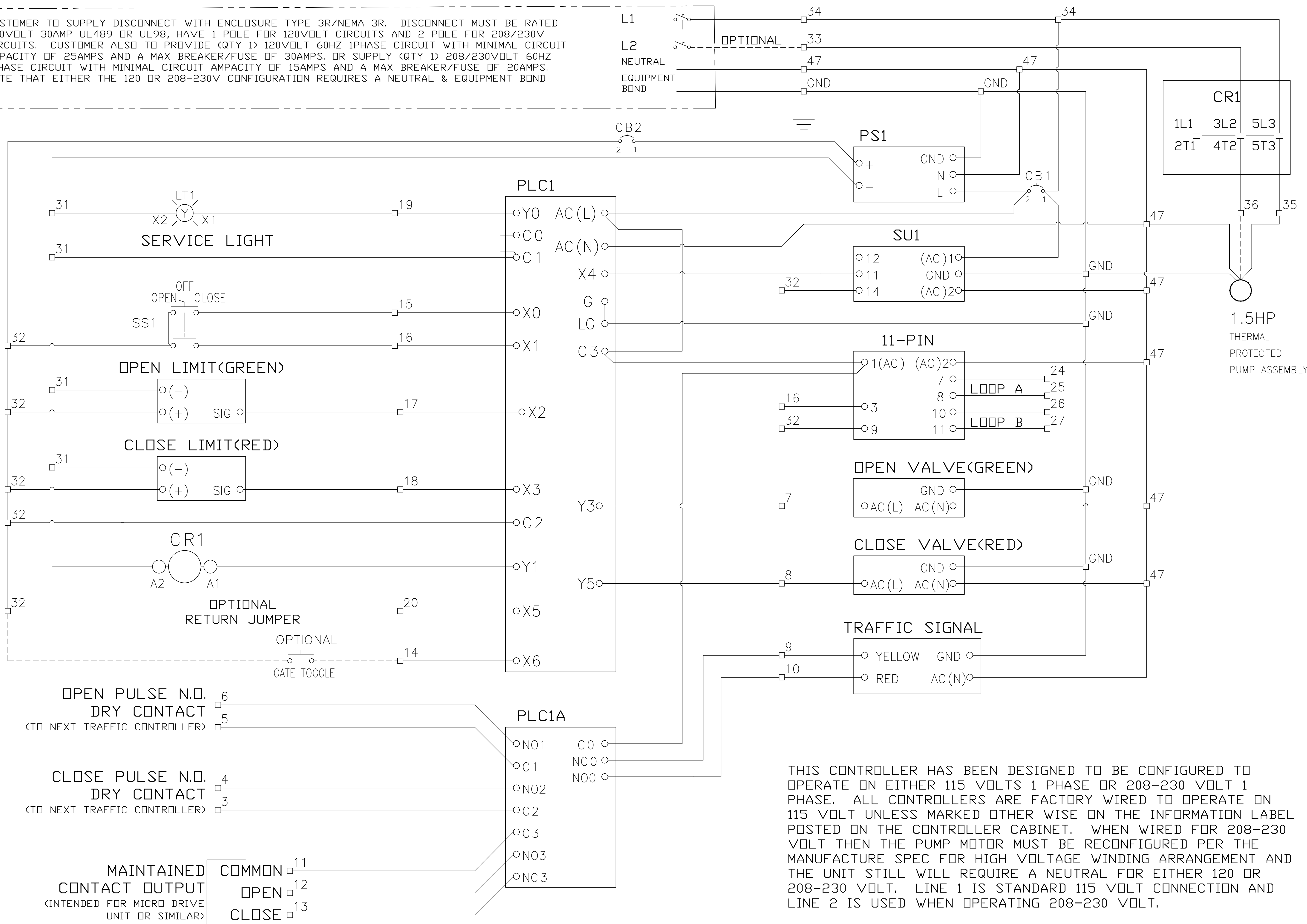

THIS CONTROLLER HAS BEEN DESIGNED TO BE CONFIGURED TO OPERATE ON EITHER 115 VOLTS 1 PHASE OR 208-230 VOLT 1 PHASE. ALL CONTROLLERS ARE FACTORY WIRED TO OPERATE ON 115 VOLT UNLESS MARKED OTHER WISE ON THE INFORMATION LABEL POSTED ON THE CONTROLLER CABINET. WHEN WIRED FOR 208-230 VOLT THEN THE PUMP MOTOR MUST BE RECONFIGURED PER THE MANUFACTURE SPEC FOR HIGH VOLTAGE WINDING ARRANGEMENT AND THE UNIT STILL WILL REQUIRE A NEUTRAL FOR EITHER 120 OR 208-230 VOLT. LINE 1 IS STANDARD 115 VOLT CONNECTION AND LINE 2 IS USED WHEN OPERATING 208-230 VOLT.



8228 Northrup Dr
Ste 100.
Punta Gorda, FL 33982



Lane-Valetre Industries Inc.
98 Maple Ave
Smithtown, NY 11787

1	1/2/25	switched pin 7&8	JL
2	4/14/25	Add drawing name	JL
NO.	DATE	REVISION	BY
DWG TITLE			
LVI TRAFFIC CONTROL PANEL LYNCH001 Program			
ENGINEER	CHECKED BY		
JOB NO	DRAWN BY JIM L.		
SCALE	DATE 04/14/2025		
DWG NO	RBG		
SHEET NO	1 OF 4		

CAD DWG FILE

LANE-VALENTE TRAFFIC CONTROLLER OPERATIONAL AND INSTALLATION INSTRUCTIONS

Controller intended use:

The controller was designed to operate a variety of hydraulic electrically controlled traffic equipment. The unit operates on 115VAC 30A circuit 2 wire or 208-230VAC 20-30A circuit 3 wire plus an equipment bond for either voltage.

Operational use:

To operate the controller at the enclosure you will find a 3 position switch(SS1) mounted into the controller enclosure. Turning the switch in either direction will cause the machine to operate. The machine will either cycle to open or to close. The unit does default in the closed position upon power up unless the optional return jumper is installed.

The controller is equipped with a service light to indicate when service is needed for the following reasons:

1. Operational counter has reached 200K cycles and a factory approved technician should perform PM service. The machine will remain operational while the service light is active.
 - 1.1. To reset the service light under this condition the open and close button must be pressed at the same time for 5 seconds. Typically this must be done at the operators booth and not at the controllers rotary switch.
2. Overrun cut out. The machine will shut down and remain inoperable when the cycle does not complete within the programmed time of 3 minutes. This is to prevent excessive damage to the machine.
 - 2.1. To reset the machine and service light under this condition the machine must be power cycled at the machines branch circuit breaker.
3. Surge Protector Failure. If neither of the above reset procedures succeed in reset of the service light then it is possible the surge protector has failed. The machine will stay operational while the service light is active.
 - 3.1. To reset the service light the surge protector must be replaced.

Installation:

The controller must be securely mounted in the RBG Buttress using all four mounting holes. Recommend a minimal 1/4-20 screw with nylon nut and washers. The customer is to provide a 30A 115V branch circuit using minimum 10GA Copper wiring or a 20A 208-230V branch circuit using minimum 12GA Copper wiring. A 30A SPST switch is needed for the 115V connection and a 20A DPST switch is needed for 208-230v connection. Refer to the terminal designation chart for wiring from the customer switch to the controllers terminal. At no time should a local disconnect not be installed within site of the controller. No additional loads should be added to the branch circuit. Disconnect housing and connection hardware shall be provided by the customer.

Control Panel Component List

Schematic Name	Make & Model	Description	QTY	UL Listing No.	AIC Rating
PS1	RHINO PSV24-30S	30W 24VDC POWER SUPPLY	1	E197592	
PLC1	DIRECTLOGIC D0-05DR	DL05 PLC W/8 INPUTS & 6 OUTPUT	1	E157382	
PLC1A	DIRECTLOGIC F0-04TRS	RELAY EXPANSION MODULE	1	EXPANSION TO D0-05DR	
CR1	WEG CWB9-11-30C03	<CR1> 3POLE 24VDC CONTACTOR	1	E202315	5KA
CR1	WEG VRB-E34	CWB9 COIL SURGE SUPPRESSOR	1	E202315	
SU1	DEHN DR-M-2P	120 VOLT SURGE PROTECTIVE DEVICE	1	E319777	
CB2	EATON FAZ-B2-1-SP	<CB2> 2A 24VDC BREAKER	1	E177451	10KA
CB1	EATON FAZ-B5-1-SP	<CB1> 5A 120VAC BREAKER	1	E177451	10KA
11-PIN	MACROMATIC 70170-D	11 PIN OCTAL RELAY SOCKET	1	E169593	
LT1	DAYTON 30G211	YELLOW LED SERVICE LIGHT 24VDC	1	E49375	
SS1	DAYTON 30G261	PANEL MOUNTED SPRING RETURN 3-POSITION SWITCH	1	E49375	

Wiring Terminal List

Make & Model	Description	QTY	UL Listing No.	AIC Rating
KONNECT-IT KN-G10SP-10	SCREW GROUND TERMINAL	5	E179129	100KA
KONNECT-IT KN-T12***	20A TERMINAL VARIOUS COLORS	27	E179129	100KA
KONNECT-IT KN-T10***	30A TERMINAL VARIOUS COLORS	12	E179129	100KA
KONNECT-IT KN-*J12	24A BLOCK JUMPER	4	E179129	
KONNECT-IT KN-*J10	32A BLOCK JUMPER	3	E179129	
KONNECT-IT KN-EB7	END BRACKET	7		
KONNECT-IT KN-ST1***	SEPARATOR VARIOUS COLORS	7		

Controller Wire

Make & Model	Description	QTY	UL Listing No.	AIC Rating
ATLAS MTW-10AWG	STRANDED COPPER		E215651	
ATLAS MTW-18AWG	STRANDED COPPER		E215651	

Wire Management Component List

Make & Model	Description	QTY	UL Listing No.	AIC Rating
AUTOMATION DIRECT DN-R35S1-2	35MM DIN RAIL SLOTTED			
IBOCO T1E	SLOTTED NARROW WIRE DUCT			

Enclosure Component List

Make & Model	Description	QTY	UL Listing No.	Enclosure Type
RITTAL JB161408HC	NEMA3R ENCLOSURE	1		4
SAGINAW SCE-16R1206LP	NEMA3R ENCLOSURE	1		3R

8228 Northup Dr
Ste 100.
Punta Gorda, FL 33982



Lane-Valetne Industries Inc.
98 Maple Ave
Smithtown, NY 11787

1	1/2/25	switched pin 7&8	JL
2	4/14/25	Add drawing name	JL
NO.	DATE	REVISION	BY
DWG TITLE			
LVI TRAFFIC CONTROL PANEL LYNCH001 Program			
ENGINEER	CHECKED BY		
JOB NO	DRAWN BY		
SCALE	DATE		
DWG NO	04/14/2025		
RBG			
SHEET NO			
2 OF 4			
WD TB			

CAD DWG FILE C:ADW

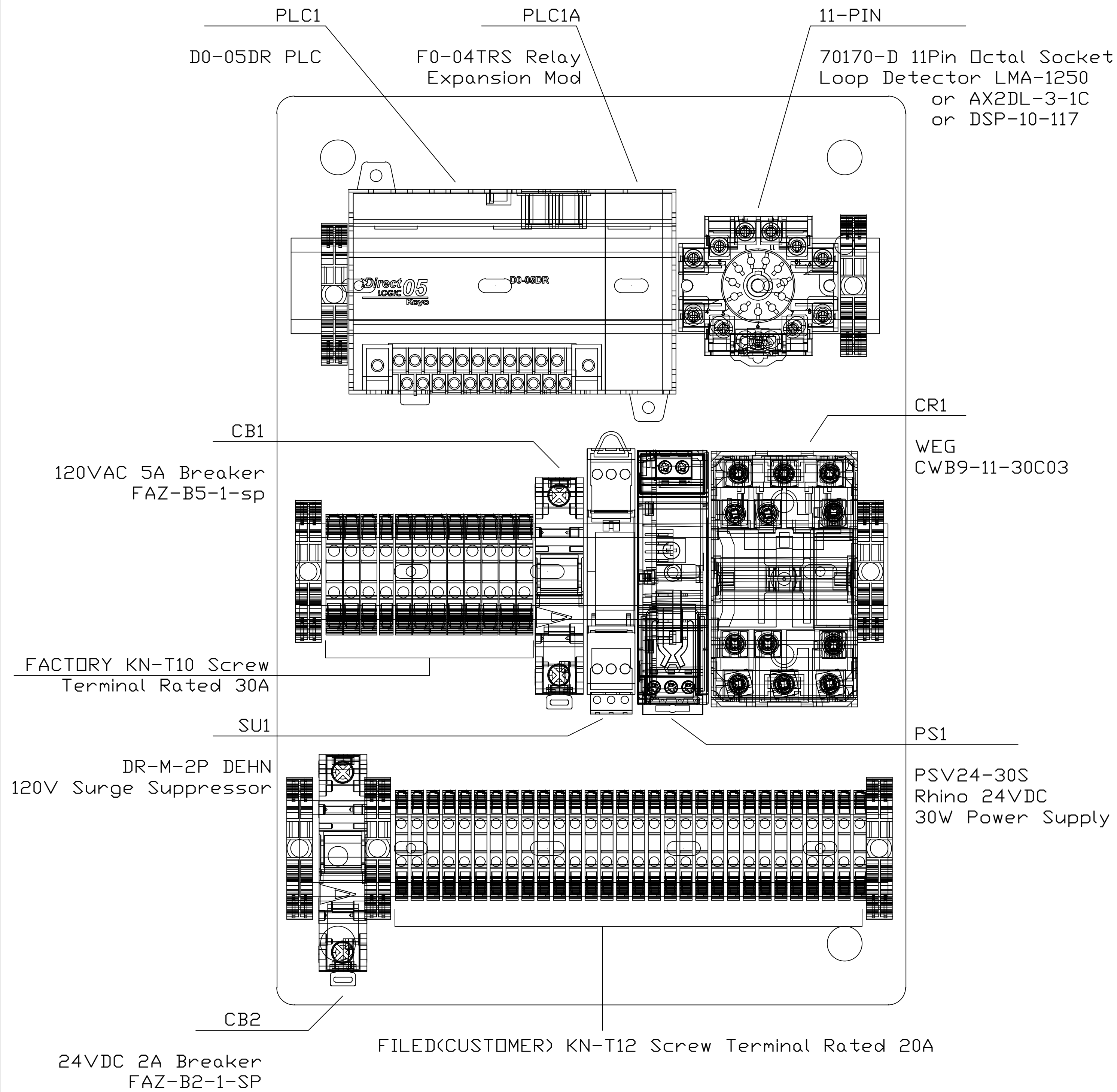

**LANE-VALENTE INDUSTRIES INC.
ROAD BLOCK FABRICATION INC.**

8228 Northup Dr. Suite 100
Punta Gorda, FL 33982
LVIttrafficcontrol.com 866.225.5584

UL 508A Industrial Panel Flie# E526550

Drawing: RBG Program: LYNCH001

BY: _____ DATE: _____

Electrical Specifications:

115V 60HZ 1PH. Min CRKT Ampacity 25A.

Max BRKR/Fuse: 30A

or

208-230V 60HZ 1PH. Min CRKT Ampacity 15A.

Max BRKR/Fuse: 20A

Short Circuit Rating: **5kA**

Enclosure: **TYPE 3R**

Largest Rated Motor: **1.5HP**

20FLA @ 115V | 11FLA @ 208V | 10FLA @ 230V

Wire Type: **USE COPPER ONLY**

For wiring and additional information please scan the QR code.

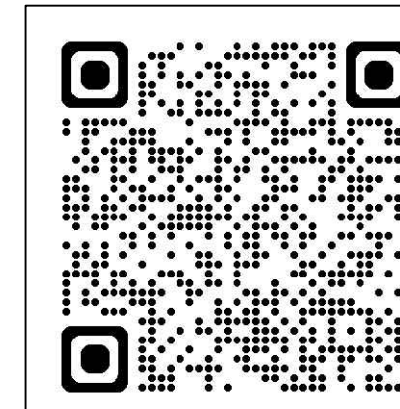

**LANE-VALENTE INDUSTRIES INC.
ROAD BLOCK FABRICATION INC.**

8228 Northup Dr. Suite 100
Punta Gorda, FL 33982

LVIttrafficcontrol.com 866.225.5584

UL 508A Industrial Panel Flie# E526550

Drawing# RBG Program: LYNCH001

Manufacture Year: _____ Serial# _____

Electrical Specifications: **115V 60HZ 1PH. Min CRKT Ampacity 25A. Max BRKR/Fuse: 30A**

or **208-230V 60HZ 1PH. Min CRKT Ampacity 15A. Max BRKR/Fuse: 20A**

Short Circuit Rating: **5kA** Enclosure: **TYPE 3R** Wire Type: **USE COPPER ONLY**

Largest Rated Motor: **1.5HP 20FLA @ 115V | 11FLA @ 208V | 10FLA @ 230V**

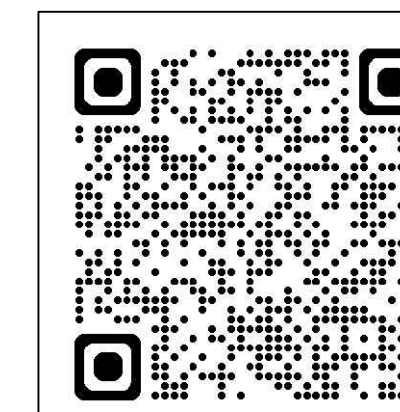

8228 Northup Dr
Ste 100.
Punta Gorda, FL 33982

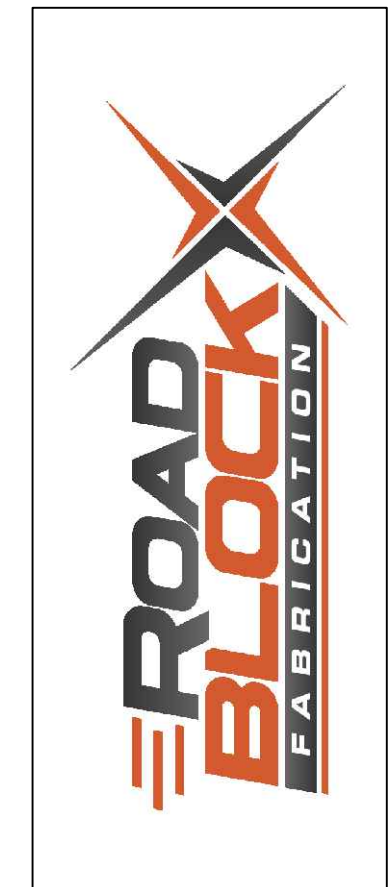

Lane-Valetne Industries Inc.
98 Maple Ave
Smithtown, NY 11787

1	1/2/25	switched pin 7&8	JL
2	4/14/25	Add drawing name	JL

NO.	DATE	REVISION	BY
-----	------	----------	----

DWG TITLE
LVI TRAFFIC CONTROL PANEL LYNCH001 Program

ENGINEER	CHECKED BY
JOB NO	DRAWN BY
SCALE	DATE
DWG NO	04/14/2025

RBG

C:\B1 DWG FILE

Controller wiring notes:

All internal control wiring other than conductors related to motor functions will be 16ga. copper MTW. Pump motor conductors within the controller are 10ga CU, MTW.

Controller Factory Wiring					
Termination Terminal	Description	MTW CU GA	Torque lb-in [Nm]	Origin Terminal	Torque lb-in [Nm]
3	CLOSE PULSE (OUTPUT)	18-16	3.5 [0.4]	C2 (F0-04TRS)	3.5 [0.4]
4	CLOSE PULSE (OUTPUT)	18-16	3.5 [0.4]	NO2 (F0-04TRS)	3.5 [0.4]
5	OPEN PULSE (OUTPUT)	18-16	3.5 [0.4]	C1 (F0-04TRS)	3.5 [0.4]
6	OPEN PULSE (OUTPUT)	18-16	3.5 [0.4]	NO1 (F0-04TRS)	3.5 [0.4]
7	OPEN VALVE	18-16	3.5 [0.4]	Y3 (D0-05DR)	3.5 [0.4]
8	CLOSE VALVE	18-16	3.5 [0.4]	Y5 (D0-05DR)	3.5 [0.4]
9	YELLOW SIGNAL	18-16	3.5 [0.4]	NO0 (F0-04TRS)	3.5 [0.4]
10	RED SIGNAL	18-16	3.5 [0.4]	NC0 (F0-04TRS)	3.5 [0.4]
15	OPEN (INPUT)	18-16	3.5 [0.4]	X0 (D0-05DR)	3.5 [0.4]
16	CLOSE (INPUT)	18-16	3.5 [0.4]	X1 (D0-05DR)	3.5 [0.4]
16	CLOSE (INPUT)	18-16	3.5 [0.4]	3 (70170-D)	3.5 [0.4]
17	OPEN LIMIT	18-16	3.5 [0.4]	X2 (D0-05DR)	3.5 [0.4]
18	CLOSE LIMIT	18-16	3.5 [0.4]	X3 (D0-05DR)	3.5 [0.4]
19	SERVICE LIGHT	18-16	3.5 [0.4]	Y0 (D0-05DR)	3.5 [0.4]
24	DET. LOOP A	18-16	3.5 [0.4]	7 (70170-D)	3.5 [0.4]
25	DET. LOOP A	18-16	3.5 [0.4]	8 (70170-D)	3.5 [0.4]
26	DET. LOOP B	18-16	3.5 [0.4]	10 (70170-D)	3.5 [0.4]
27	DET. LOOP B	18-16	3.5 [0.4]	11 (70170-D)	3.5 [0.4]
31	24VDC NEGATIVE	18-16	3.5 [0.4]	C0 (D0-05DR)	3.5 [0.4]
31	24VDC NEGATIVE	18-16	3.5 [0.4]	(-) LT1	7 [0.8]
31	24VDC NEGATIVE	18-16	3.5 [0.4]	(-) PSV24-30S	4.5 [1.5]
31	24VDC NEGATIVE	18-16	3.5 [0.4]	A2 (CR1)	1.0 [0.74]
32	24VDC POSITIVE	18-16	3.5 [0.4]	2 (CB2)	21.2 [2.4]
32	24VDC POSITIVE	18-16	3.5 [0.4]	COMMON SS1	7 [0.8]
32	24VDC POSITIVE	18-16	3.5 [0.4]	11 (DR-M-2P)	4.5 [1.5]
32	24VDC POSITIVE	18-16	3.5 [0.4]	C2 (D0-05DR)	3.5 [0.4]
33	LINE 2	10	4.4 [0.5]	3L2 (CR1)	1.25 [1.7]
34	LINE 1	10	4.4 [0.5]	5L3 (CR1)	1.25 [1.7]
34	LINE 1	18-16	3.5 [0.4]	1 (CB1)	21.2 [2.4]
35	LINE 1 (OUT)	10	4.4 [0.5]	5T3 (CR1)	1.25 [1.7]
36	LINE 2 (OUT)	10	4.4 [0.5]	4T2 (CR1)	1.25 [1.7]
47	NEUTRAL	18-16	4.4 [0.5]	N (PSV24-30S)	4.5 [1.5]
47	NEUTRAL	18-16	4.4 [0.5]	AC(N) (D0-05DR)	3.5 [0.4]
47	NEUTRAL	18-16	4.4 [0.5]	AC(N) (DR-M-2P)	4.5 [1.5]
47	NEUTRAL	18-16	4.4 [0.5]	AC(N) (70170-D)	3.5 [0.4]
47	NEUTRAL	18-16	4.4 [0.5]	AC(N) OPEN VALVE	N/A
47	NEUTRAL	16	4.4 [0.5]	AC(N) CLOSE VALVE	N/A
47	NEUTRAL	16	4.4 [0.5]	TRAFFIC SIGNAL	N/A

Customer Field Wiring			
Terminal #	Description	Torque lb-in [Nm]	Min. CU. Wire GA.
3	CLOSE PULSE N.O. DRY CONTACT 30VDC 3A	3.5 [0.4]	18 - 12
4	CLOSE PULSE N.O. DRY CONTACT 30VDC 3A	3.5 [0.4]	18 - 12
5	OPEN PULSE N.O. DRY CONTACT 30VDC 3A	3.5 [0.4]	18 - 12
6	OPEN PULSE N.O. DRY CONTACT 30VDC 3A	3.5 [0.4]	18 - 12
9	YELLOW SIGNAL LIGHT (120V)	3.5 [0.4]	18 - 12
10	RED SIGNAL LIGHT (120V)	3.5 [0.4]	18 - 12
11	MAINTAINED CONTACT OUTPUT COMMON 30VDC 3A	3.5 [0.4]	18 - 12
12	MAINTAINED CONTACT OUTPUT OPEN 30VDC 3A	3.5 [0.4]	18 - 12
13	MAINTAINED CONTACT OUTPUT CLOSE 30VDC 3A	3.5 [0.4]	18 - 12
14	OPTIONAL GATE TOGGLE (MOMENTARY INPUT ONLY)	3.5 [0.4]	18 - 12
15	OPEN (N.O. MOMENTARY CONTACT INPUT)	3.5 [0.4]	18 - 12
16	CLOSE (N.O. MOMENTARY CONTACT INPUT)	3.5 [0.4]	18 - 12
24	DETECTION LOOP A	3.5 [0.4]	18 - 12
25	DETECTION LOOP A	3.5 [0.4]	18 - 12
26	DETECTION LOOP B	3.5 [0.4]	18 - 12
27	DETECTION LOOP B	3.5 [0.4]	18 - 12
32	OPEN/CLOSE/TOGGLE COMMON	3.5 [0.4]	18 - 12
33	LINE 2 OPTIONAL	4.4 [0.5]	12 - 10
34	LINE 1	4.4 [0.5]	12 - 10
47	NEUTRAL	4.4 [0.5]	12 - 10
≡ GND	EQUIPMENT BOND	4.4 [0.5]	12 - 10

Factory Component Wiring					
Component Terminal	Description	Torque lb-in [Nm]	Connection Point	Torque lb-in [Nm]	Min. CU. Wire GA.
A1	CR1 COIL	1.0 [0.74]	Y1 (D0-05DR)	3.5 [0.4]	18 - 16 MTW
(+)	PSV24-30S	4.5 [1.5]	1 (CB2)	21.2 [2.4]	18 - 16 MTW
11	DR-M-2P	4.5 [1.5]	32	3.5 [0.4]	18 - 16 MTW
14	DR-M-2P	4.5 [1.5]	X4 (D0-05DR)	3.5 [0.4]	18 - 16 MTW
2	CB1	21.2 [2.4]	L (PSV24-30S)	4.5 [1.5]	18 - 16 MTW
2	CB1	21.2 [2.4]	AC(L) (D0-05DR)	3.5 [0.4]	18 - 16 MTW
AC(L)	D0-05DR	3.5 [0.4]	C3 (D0-05DR)	3.5 [0.4]	18 - 16 MTW
C3	D0-05DR	3.5 [0.4]	AC(L) (DR-M-2P)	4.5 [1.5]	18 - 16 MTW
AC(L)	DR-M-2P	4.5 [1.5]	1 (70170-D)	3.5 [0.4]	18 - 16 MTW
1	70170-D	3.5 [0.4]	C0 (F0-04TRS)	3.5 [0.4]	18 - 16 MTW
BLUE	OPEN LIMIT SWITCH	N/A	31(-)	3.5 [0.4]	COMPONENT PROVIDED
BROWN	OPEN LIMIT SWITCH	N/A	32(+)	3.5 [0.4]	COMPONENT PROVIDED
BLACK	OPEN LIMIT SWITCH	N/A	17	3.5 [0.4]	COMPONENT PROVIDED
BLUE	CLOSE LIMIT SWITCH	N/A	31(-)	3.5 [0.4]	COMPONENT PROVIDED
BROWN	CLOSE LIMIT SWITCH	N/A	32(+)	3.5 [0.4]	COMPONENT PROVIDED
BLACK	CLOSE LIMIT SWITCH	N/A	18	3.5 [0.4]	COMPONENT PROVIDED
MOTOR(L1)	LINE 1 FROM MOTOR	N/A	35	3.5 [0.4]	12 THWN-2
OPTIONAL (L2) MOTOR	LINE 2 FROM MOTOR	N/A	36	3.5 [0.4]	12 THWN-2
MOTOR(N)	NEUTRAL FROM MOTOR	N/A	47	4.4 [0.5]	12 THWN-2

8228 Northrup Dr
Ste 100.
Punta Gorda, FL 33982



Lane-Valetre Industries Inc.
98 Maple Ave
Smithtown, NY 11787

1	1/2/25	Switched Pin 7&8	JL
2	4/14/25	Add drawing name	JL
NO.	DATE	REVISION	BY
DWG TITLE			
LVI TRAFFIC CONTROL PANEL LYNCH001 Program			
ENGINEER	CHECKED BY		
JOB NO	DRAWN BY		
SCALE	DATE		
DWG NO	04/14/2025		
RBC			
4 OF 4			

CAD DWG FILE